

REV.	ECN NO.	DATE
01	ADD P/N	2014.04.04

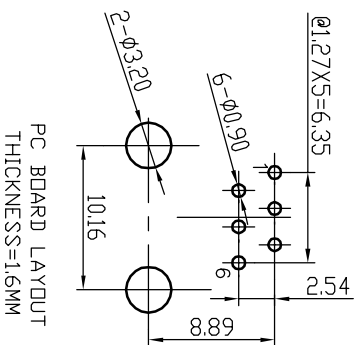
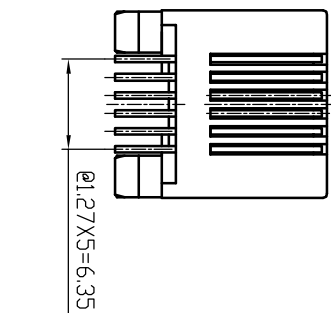
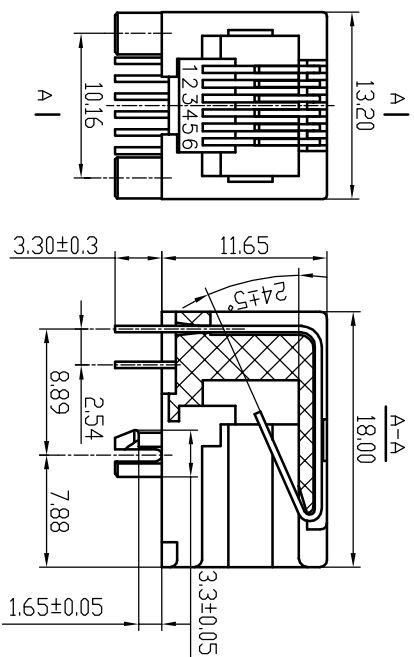

A

1

2

3

4

A

B

B

NOTES:

ELECTRICAL:

- VOLTAGE RATING : 125 VAC RMS.
- CURRENT RATING : 1.5 AMPS@25° C
- CONTACT RESISTANCE : 20 MΩ MIN @500VDC.
- INSULATION RESISTANCE : 1000 MΩ MIN @500VDC.
- WITHSTAND VOLTAGE : 1000 VAC RMS, contact to contact or 1500VDC, contact to screen and test panel @0.5mA 50Hz or 60Hz 1 min.

MECHANICAL:

- HOUSING&INSERT& MATERIAL : PBT/PA66 UI94V-0.
- CONTACT MATERIAL : PHOSPHOR BRONZE φ0.46mm
- CONTACT PLATING : GOLD PLATING OVER NICKEL.
- MATING/UNMATING FORCE: : 30N Max..
- RETENTION STRENGTH : 50N for 60s±5s.
- DURABILITY : 750 CYCLES MIN.

- ENVIRONMENTAL:
- STORAGE TEMPERATURE : -40°C to +85°C RELATIVE HUMIDITY<80%
 - OPERATION TEMPERATURE : -40°C to +85°C
- MATES WITH MODULAR PLUG CONFORMING TO IEC-60603 & TIA-1096
- ROHS PART NUMBER:

P/N	DESCRIPTION	MATERIAL COLOR
10215366B004	RJ11 5321 6P6C/5321 JACK 6P6C 3u"	PBT BLACK
10215366A007	RJ11 5321 6P6C/5321 JACK 6P6C C/F	PBT BLACK

Rohs Compliant

CZT

温州意华连接器股份有限公司
WENZHOU YIHUA CONNECTOR CO.,LTD

TOLERANCES

Material:

SEE_NOTE

Designed:

Ygq

NAME:

RJ11 1X1 5321 6P6C JACK

00~15 ± 0.15

15~30 ± 0.20

30~ ± 0.25

ANGLES ±1°

Finish:

SEE_NOTE

Checked:

DWG NO:

ES3QWY-1094-9

SHEET 1 OF 1

Approved:

PART NO:

SEE_NOTE

REV.

01

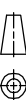

A4

SCALE

UNIT

CUSTOMER:

MODEL NO:

SIZE

1:1

mm

1

2

3

4

D

C

D

C