

WS05-4RUL

Transient Voltage Suppressor

Features

- Solid-state silicon-avalanche technology
- 400Watts Peak Pulse Power per Line ($t_p=8/20\mu s$)
- Low operating and clamping voltage
- Up to four I/O Lines of Protection
- Ultra low capacitance:1.5pF
- Low Leakage
- Low operating voltage:5V

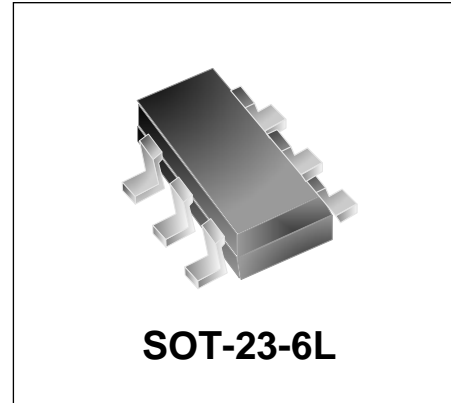

IEC COMPATIBILITY (EN61000-4)

- IEC 61000-4-2 (ESD) $\pm 15kV$ (air), $\pm 8kV$ (contact)
- IEC 61000-4-4 (EFT) 40A (5/50ns)
- IEC 61000-4-5 (Lightning) 20A (8/20 μs)

Mechanical Characteristics

- SOT-23-6L package
- Molding compound flammability rating: UL 94V-0
- Marking: Marking Code
- Packaging: Tape and Reel
- RoHS/WEEE Compliant

Applications

- Video/Graphics Card
- Handheld & Portable Electronics
- PC/Notebook USB2.0/IEEE1394 ports
- 10/100/1000 Ethernet
- DVI interfaces
- Wireless data (WAN/LAN) systems

Circuit Diagram

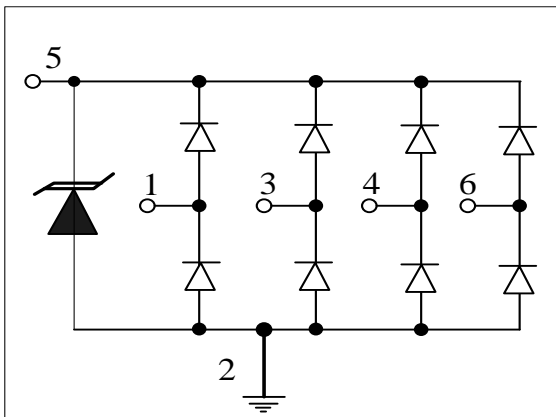

Schematic & PIN Configuration

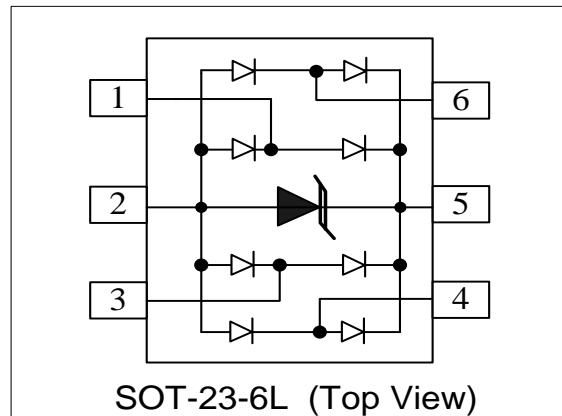

Absolute Maximum Rating			
Rating	Symbol	Value	Units
Peak Pulse Power ($t_p = 8/20\mu s$)	P _{PP}	400	Watts
Peak Pulse Current ($t_p = 8/20\mu s$)	I _{pp}	20	A
Operating Temperature	T _J	-55 to + 125	°C
Storage Temperature	T _{STG}	-55 to +150	°C

Electrical Parameters (T=25°C)

Symbol	Parameter
I _{PP}	Maximum Reverse Peak Pulse Current
V _C	Clamping Voltage @ I _{PP}
V _{RWM}	Working Peak Reverse Voltage
I _R	Maximum Reverse Leakage Current @ V _{RWM}
V _{BR}	Breakdown Voltage @ I _T
I _T	Test Current
I _F	Forward Current
V _F	Forward Voltage @ I _F

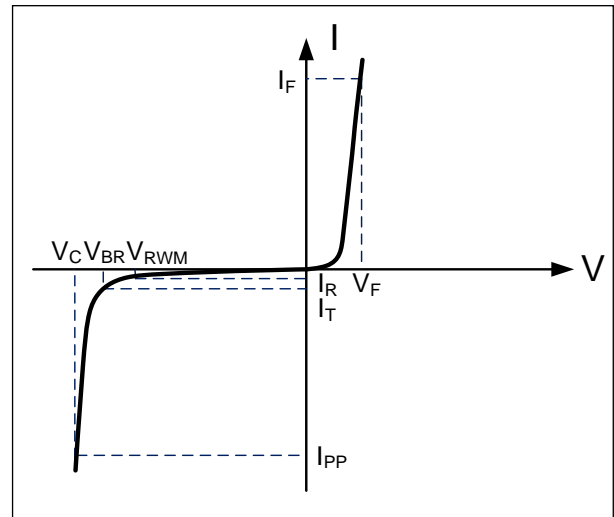

Electrical Characteristics

WS05-4RUL						
Parameter	Symbol	Conditions	Minimum	Typical	Maximum	Units
Reverse Stand-Off Voltage	V _{RWM}	Pin5 to pin2			5.0	V
Reverse Breakdown Voltage	V _{BR}	I _T =1mA Pin 5 to pin2	6.0			V
Reverse Leakage Current	I _R	V _{RWM} =5V, T=25°C Pin 5 to pin2			5	µA
Forward Voltage	V _F	I _T =10mA			1.2	
Clamping Voltage	V _C	I _{PP} =5A, t _p =8/20µs I/O pin to GND		16.5	19	V
Junction Capacitance	C _j	V _R = 0V, f = 1MHz I/O pin to GND		3		pF
		V _R = 0V, f = 1MHz Between I/O pins		1.5		pF

Typical Characteristics

Figure 1: Peak Pulse Power vs. Pulse Time

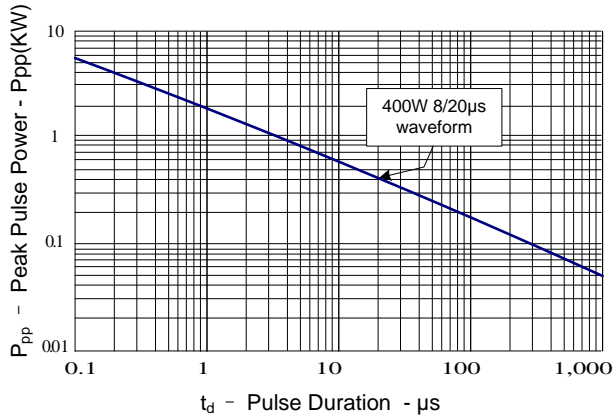

Figure 2: Power Derating Curve

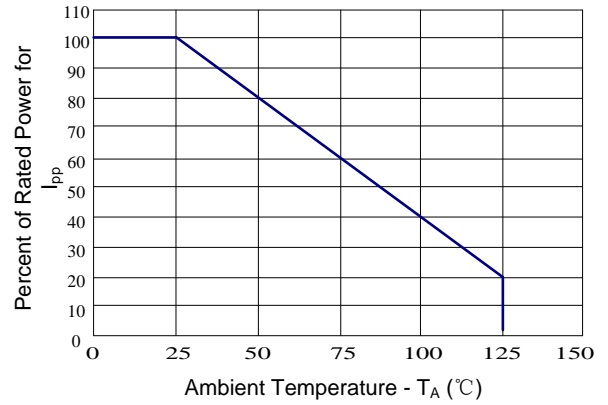

Figure 3: Pulse Waveform

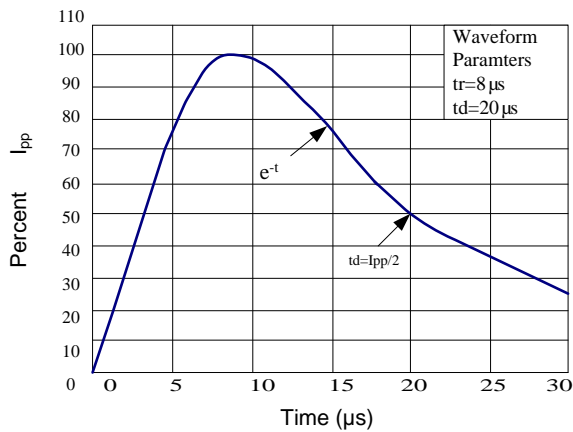

Figure 4: Clamping Voltage vs. Peak Pulse Current

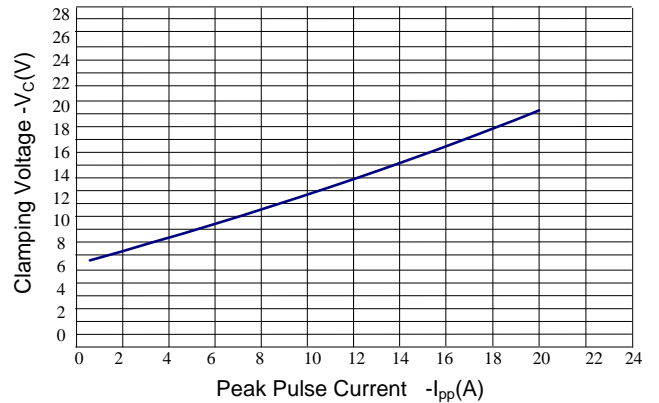

Figure 5: Capacitance vs. Reverse Voltage

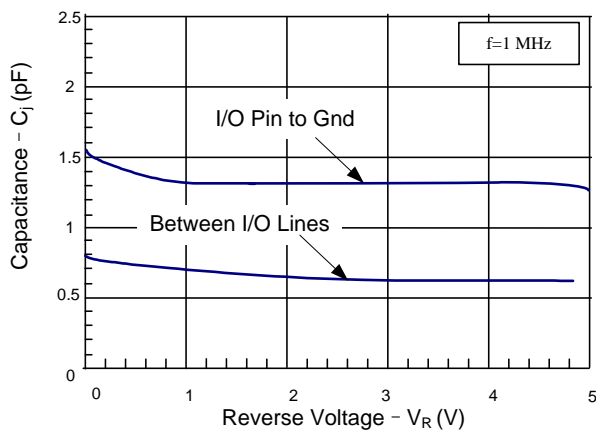
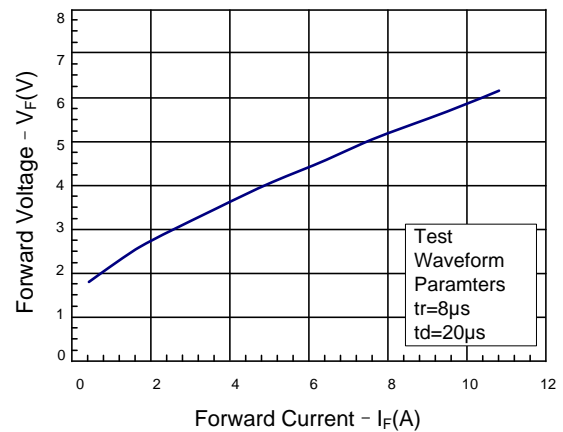

Figure 6: Forward Voltage vs. Forward Current



Application Information

Device Connection Options for Protection of Four High-Speed Data Lines

The WS05-4RUL TVS is designed to protect four data lines from transient over-voltages by clamping them to a fixed reference. When the voltage on the protected line exceeds the reference voltage (plus diode V_F) the steering diodes are forward biased, conducting the transient current away from the sensitive circuitry. Data lines are connected at pins 1, 3, 4 and 6. The negative reference (R_{EF1}) is connected at pin 2. This pin should be connected directly to a ground plane on the board for best results. The path length is kept as short as possible to minimize parasitic inductance. The positive reference (R_{EF2}) is connected at pin 5. The options for connecting the positive reference are as follows:

1. To protect data lines and the power line, connect pin 5 directly to the positive supply rail (V_{CC}). In this configuration the data lines are referenced to the supply voltage. The internal TVS diode prevents over-voltage to the supply rail.

Data Line and Power Supply Protection Using V_{CC} as reference

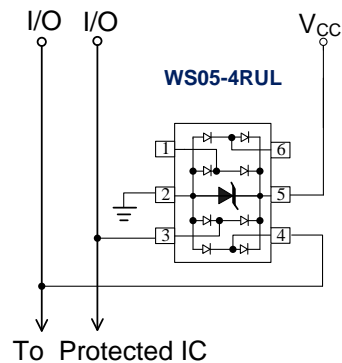

2. The WS05-4RUL can be isolated from the power supply by adding a series resistor between pin 5 and V_{CC} . A value of 100k Ω is recommended. The internal TVS and steering diodes remains biased, providing the advantage of lower capacitance.

Data Line Protection with Bias and Power Supply Isolation Resistor

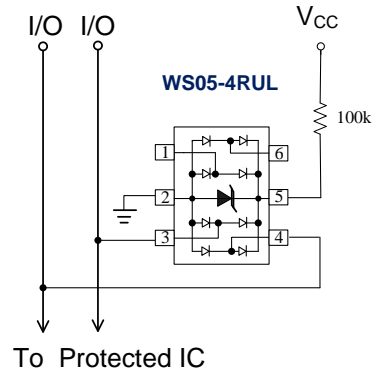

3. In applications where no positive supply reference is available, or complete supply isolation is desired, the internal TVS may be used as the reference. In this case, pin 5 is not connected. The steering diodes will begin to conduct when the voltage on the protected line exceeds the working voltage of the TVS (plus one diode drop).

Data Line Protection Using Internal TVS Diode as Reference

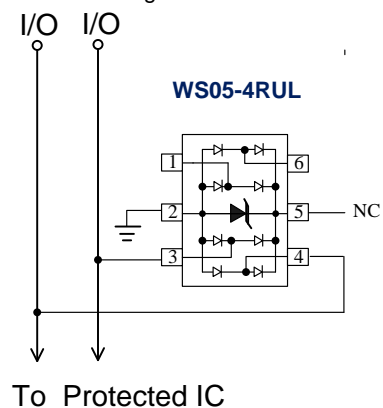

Typical Applications

Video Interface Protection

Video interfaces are susceptible to transient voltages resulting from electrostatic discharge (ESD) and “hot plugging” cables. If left unprotected, the video interface IC may be damaged or even destroyed. Protecting a high-speed video port presents some unique challenges. First, any added protection device must have extremely low capacitance and low leakage current so that the integrity of the video signal is not compromised. Second, the protection component must be able to absorb high voltage transients without damage or degradation. As a minimum, the device should be rated to handle ESD voltages per IEC 61000-4-2, level 4 ($\pm 15\text{kV}$ air, $\pm 8\text{kV}$ contact). The clamping voltage of the device (when conducting high current ESD pulses) must be sufficiently low enough to protect the sensitive CMOS IC. If the clamping voltage is too high, the “protected” device may latch-up or be destroyed. Finally, the device must take up a relatively small amount of board space, particularly in portable applications such as notebooks and handhelds. The WS05-4RUL is designed to meet or exceed all of the above criteria. A typical video interface protection circuit is shown in Figure 1. All exposed lines are protected including R, G, B, H-Sync, V-Sync, and the ID lines for plug and play monitors.

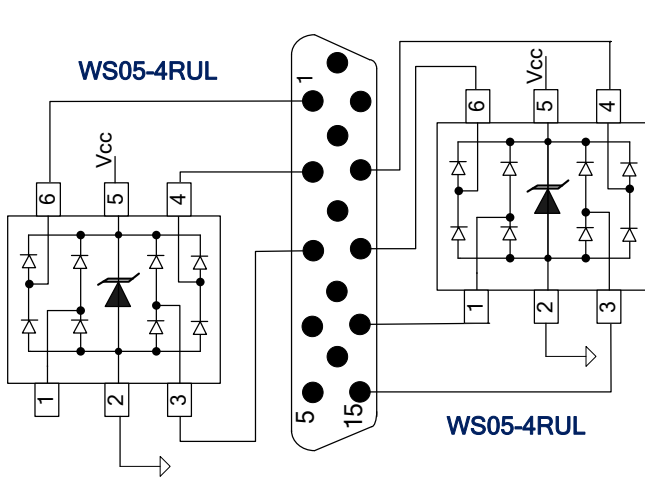

Figure 1 Video Interface Protection

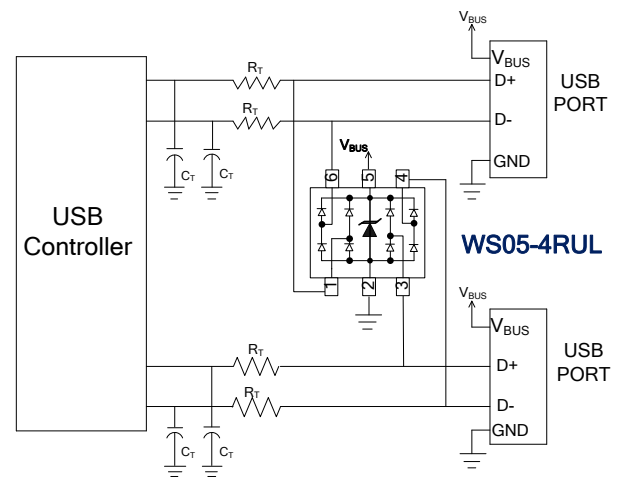

Figure 2 Dual USB Port Protection

Universal Serial Bus ESD Protection

The WS05-4RUL may also be used to protect the USB ports on monitors, computers, peripherals or portable systems. Each device will protect up to two USB ports (Figure 2). When the voltage on the data lines exceed the bus voltage (plus one diode drop), the internal rectifiers are forward biased conducting the transient current away from the protected controller chip. The TVS diode directs the surge to ground. The TVS diode also acts to suppress ESD strikes directly on the voltage bus. Thus, both power and data pins are protected with a single device.

10/100 Ethernet Protection

Ethernet ICs are vulnerable to damage from electrostatic discharge (ESD). The internal protection in the PHY chip, if any, often is not enough due to the high energy of the discharges specified by IEC 61000-4-2. If the discharge is catastrophic, it will destroy the protected IC. If it is less severe, it will cause latent failures that are very difficult to find.

10/100 Ethernet operates at 125MHz clock over a twisted pair interface. In a typical system, the twisted pair interface for each port consists of two differential signal pairs: one for the transmitter and one for the receiver, with the transmitter input being the most sensitive to damage. The fatal discharge occurs differentially across the transmit or receive line pair and is capacitively coupled through the transformer to the Ethernet chip. Figure 3 shows how to design the WS05-4RUL on the line side of a 10/100 Ethernet port to provide differential mode protection. The common mode isolation of the transformer will provide common mode protection to the rating of the transformer isolation which is usually >1.5kV. If more common mode protection is needed, figure 4 shows how to design the WS05-4RUL on the IC side of the 10/100 Ethernet circuit to provide differential and common mode protection. The WS05-4RUL can not be grounded on the line side because the hi-pot test requires the line side not to be grounded.

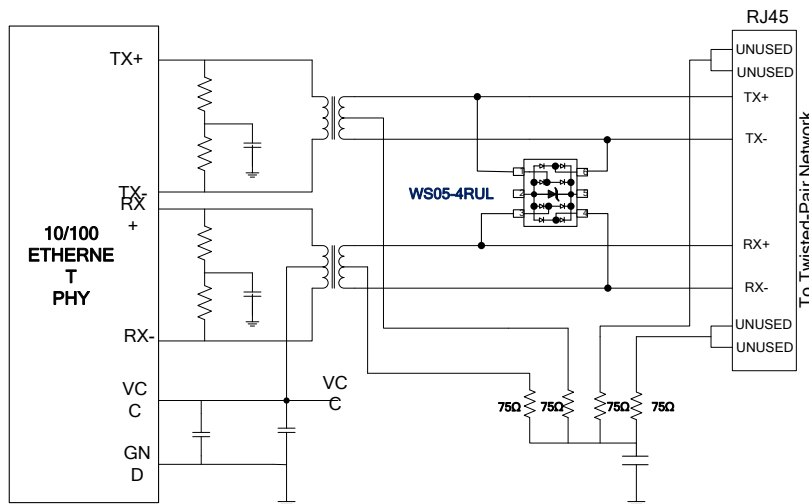

10/100 Ethernet Differential Protection

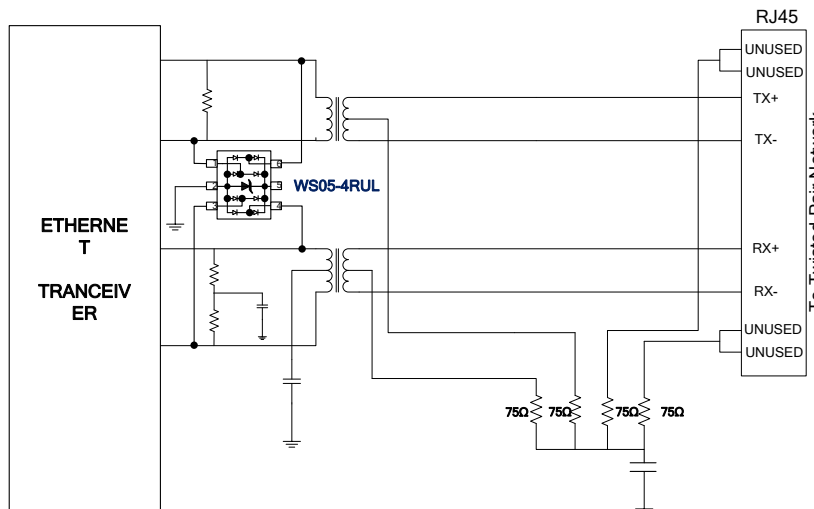

10/100 Ethernet Differential and Common Mode Protection

Outline Drawing – SOT-23-6L

PACKAGE OUTLINE

SEE DETAIL A

DETAIL A

DIMENSIONS		
DIM	INCHES	MILLIMETERS
Z	0.141	3.60
G	0.055	1.40
P	0.037	0.95
X	0.024	0.60
Y	0.043	1.10
C	(0.098)	(2.50)

SOT-23-6L

DIMENSIONS

SYMBOL	INCHES		MILLIMETER	
	MIN	MAX	MIN	MAX
A	0.041	0.049	1.050	1.250
A1	0.000	0.004	0.000	0.100
A2	0.041	0.045	1.050	1.150
D	0.111	0.119	2.820	3.020
E	0.059	0.067	1.500	1.700
E1	0.104	0.116	2.650	2.950
e	0.037(BSC)		0.950(BSC)	
e1	0.071	0.079	1.800	2.000
L	0.012	0.024	0.300	0.600
θ	0°	8°	0°	8°

Notes
THIS LAND PATTERN IS FOR REFERENCE PURPOSES ONLY. CONSULT YOUR MANUFACTURING GROUP TO ENSURE YOUR COMPANY'S MANUFACTURING GUIDELINES ARE MET.

Marking Codes

Part Number	WS05-4RUL
Marking Code	05U

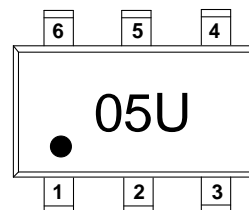

CONTACT INFORMATION

SHANGHAI CHANGYUAN WAYON CIRCUIT PROTECTION CO., LTD.
 No.1001, Shiwan(7) Road, Pudong District, Shanghai, P.R.China.201202
 Tel: 86-21-50310888 Fax: 86-21-50757680 Email: market@way-on.com
 WAYON website: <http://www.way-on.com>

For additional information, please contact your local Sales Representative.



® and **Way-On** ® are registered trademarks of Wayon Corporation.