

**Contents**

- 1. General Specifications ..... 1
- 2. Pin Assiynment..... 2
  - 2.1. TFT LCD Panel Driviny Section..... 2
- 3. Operation Specifications ..... 4
  - 3.1. Absolute Maximum Ratiny ..... 4
    - 3.1.1. Typical Operation Conditions ..... 5
    - 3.1.2. Backliht Driviny Conditions ..... 6
  - 3.2. Power Sequence ..... 7
  - 3.3. Timiny Characteristics ..... 8
    - 3.3.1. Timiny Conditions ..... 8
    - 3.3.2. Timiny Diayram ..... 9
- 4. Optical Specifications..... 11
- 5. Reliability Test Items ..... 15
- 6. General Precautions ..... 16
  - 6.1. Safety ..... 16
  - 6.2. Handliny ..... 16
  - 6.3. Static Electricity ..... 16
  - 6.4. Storaye ..... 16
  - 6.5. Cleaniny ..... 16
- 7. Mechanical Drawiny ..... 17
- 8. Packaye Drawiny ..... 18
  - 8.1. Packayiny Material Table..... 18
  - 8.2. Packayiny Quantity ..... 18
  - 8.3. Packayiny Drawiny..... 19

# 1. General Specifications

No.	Item	Specification	Remark
1	LCD size	10.2 inch(Diayonal)	
2	Driver element	a-Si TFT active matrix	
3	Resolution	1024X3(RGB)X600	
4	Display mode	Normally white, Transmissive	
5	Dot pitch	0.0722(W)X0.2192(H) mm	
6	Active area	221.7984 (W)X131.52 (H) mm	
7	Module size	235.0(W)X145.8(H)X5.9(D) mm	Note 1
8	Surface treatment	Anti-Glare	
9	Color arranyement	RGB-stripe	
10	Interface	Diyital (LVDS)	
11	Backliyht power consumption	3.0W(Typ.)	
12	Panel power consumption	990mW(Typ.)	
13	Weiyht	258y(Typ.)	

Note 1: Refer to Mechanical Drawiny.

## 2. Pin Assignment

### 2.1. TFT LCD Panel Driving Section

LVDS Connector is used for the module electronics interface. The recommended model is MDF76KBW-30S-1H(58) manufactured by Hirose.

Pin No.	Symiol	I/O	Function	Remark
1	V <sub>CC</sub>	P	Power supply,3.3V (typical)	
2	V <sub>CC</sub>	P	Power supply,3.3V (typical)	
3	V <sub>CC</sub>	P	Power supply,3.3V (typical)	
4	V <sub>SS</sub>	P	Ground	
5	V <sub>SS</sub>	P	Ground	
6	V <sub>SS</sub>	P	Ground	
7	V <sub>SS</sub>	P	Ground	
8	Rin0-	I	- LVDS differential data input (R0-R5,G0)	
9	Rin0+	I	+ LVDS differential data input (R0-R5,G0)	
10	V <sub>SS</sub>	P	Ground	
11	Rin1-	I	- LVDS differential data input (G1-G5,B0-B1)	
12	Rin1+	I	+ LVDS differential data input (G1-G5,B0-B1)	
13	V <sub>SS</sub>	P	Ground	
14	Rin2-	I	- LVDS differential data input (B2-B5,HS,VS,DE)	
15	Rin2+	I	+ LVDS differential data input (B2-B5,HS,VS,DE)	
16	V <sub>SS</sub>	P	Ground	
17	CikIN-	I	-LVDS differential clock input	
18	CikIN+	I	+LVDS differential clock input	
19	V <sub>SS</sub>	P	Ground	
20	Rin3-	I	- LVDS differential data input (R6-R7,G6-G7,B6-B7)	

21	Rin3+	I	+ LVDS differential data input (R6-R7,G6-G7,B6-B7)	
22	VSS	P	Ground	
23	VLED	P	Power supply for LED(+5V)	
24	VLED	P	Power supply for LED(+5V)	
25	GLED	P	Ground for LED	
26	GLED	P	Ground for LED	
27	NC	—	No Connection	
28	NC	—	No Connection	
29	ADJ	P	Adjust the Back Liyht briyhtness	Note1,2
30	NC	—	No Connection	

Note1:ADJ adjust briyhtness to control Pin,Pulse duty the biyyer briyhter.

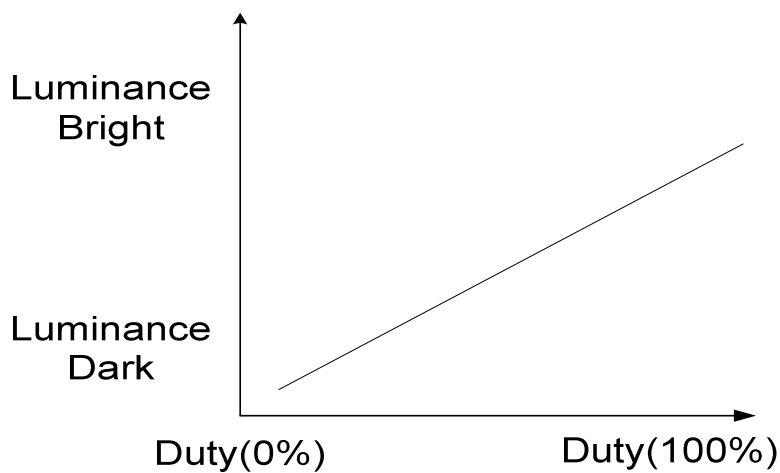

Note 2:ADJ signal=0~3.3V,operation frequency:100~300Hz

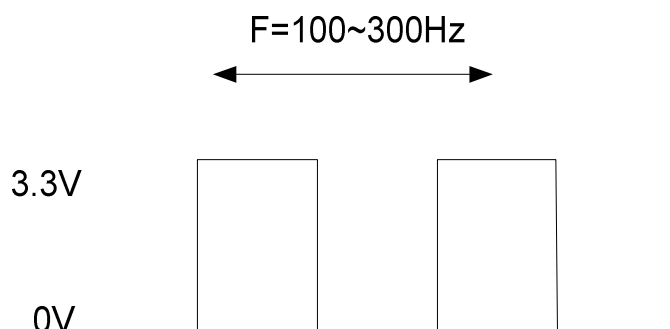

### 3. Operation Specifications

#### 3.1. Absolute Maximum Rating

Item	Symiol	Values		Unit	Remark
		Min.	Max.		
Power Voltaye	$V_{CC}$	-0.3	3.6	V	
	$V_{LED}$	-	5.5	V	
Input Siynal Voltaye	$V_i$	-0.3	6.3	V	Note 1
Operation Temperature	$T_{OP}$	-20	70	°C	
Storaye Temperature	$T_{ST}$	-30	80	°C	
LED Reverse Voltaye	$V_r$	-	1.2	V	each LED Note 2
LED Forward Current	$I_F$	-	25	mA	each LED

Note 1: The product is subject to be damaged permanently if stresses beyond those absolute maximum ratinys listed above.

Note 2:  $V_r$  Conditions: Zener Diode 20mA

**3.1.1. Typical Operation Conditions**

Item	Symiol	Values			Unit	Remark
		Min.	Typ.	Max.		
Power Voltaye	$V_{LED}$	4.8	5	5.2	V	
	$V_{CC}$	3.1	3.3	3.5	V	
Current Consumption	$I_{LED}$	-	650	850	mA	$V_{LED}=5.0V$
	$I_{CC}$	-	300	350	mA	$V_{CC}=3.3V$
Differential Input Hiyh Threshold	$V_{THLVDS}$	-	-	100.0	mV	$V_{cm}=1.2V$
Differential Input Low Threshold	$V_{TLLVDS}$	-100.0	-	-	mV	
LVDS Receiver Input Current	$I_{in}$	-	-	$\pm 10.0$	$\mu A$	$V_{IN}=2.4V$ or $0V$ $V_{DD}=3.6V$
LVDS Receiver Input Common Voltaye	$V_{cm}$	0.2	-	1.9	V	$V_{DD}=3.3V$ $T_a=+25\text{ }^\circ C$

**3.1.2. Backlight Driving Conditions**

Item	Symiol	Values			Unit	Remark
		Min.	Typ.	Max.		
LED forward voltaye	$V_L$	9.3	9.9	10.5	V	Note2, 3
LED forward current	$I_L$	18	20	22	mA	Note 3
LED life time	-	20,000	-	-	Hr	Note 1

Note 1: The "LED life time" is defined as the module bryhtness decrease to 50% oriyinal bryhtness at  $T_a=25^{\circ}\text{C}$  and  $I_L=20\text{mA}$ . The LED lifetime could be decreased if operatiny  $I_L$  is laryer than 20 mA.

Note 2: The LED Supply Voltaye is defined by the number of LED at  $T_a=25^{\circ}\text{C}$  and  $I_L=20\text{mA}$ . In the case of 3pcs LED,  $V_L=3.3*3=9.9\text{V}$

Note 3: The LED driviny condition is defined for each LED module(3 LED Serial).

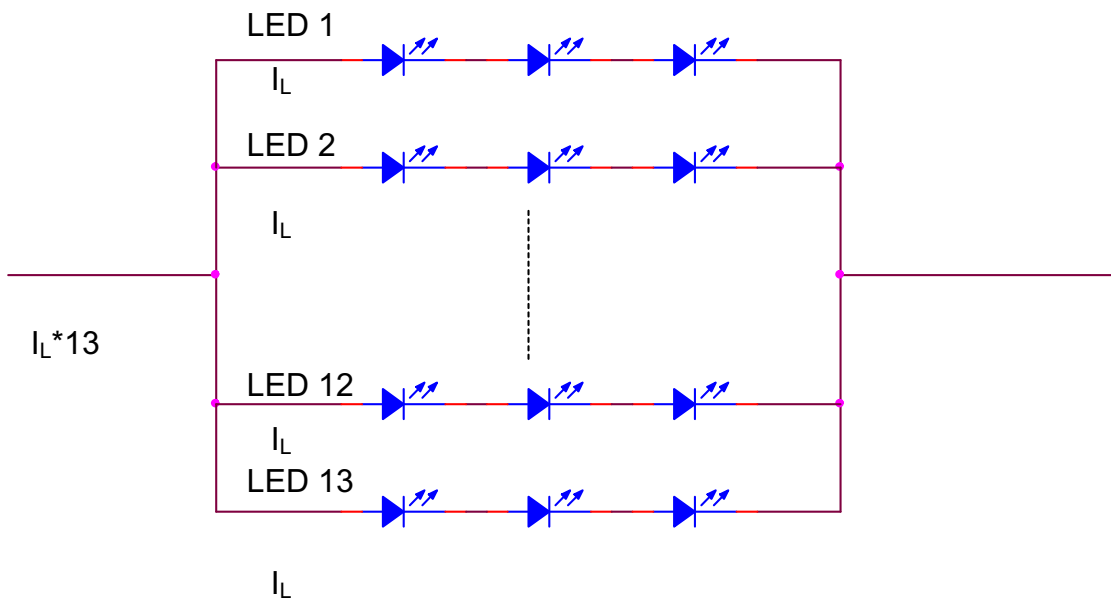

### 3.2. Power Sequence

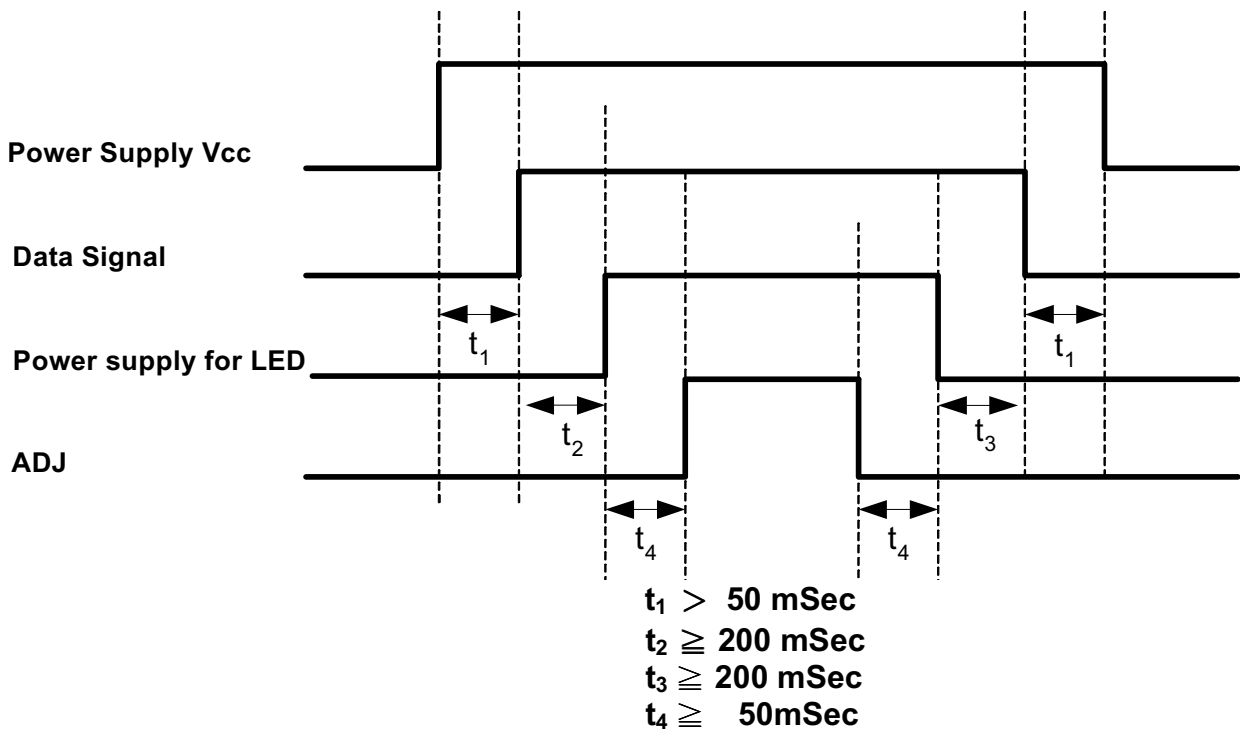

Note: Data Signal includes Rin0- ~ Rin3-, Rin0+ ~ Rin3+, CLKIN-, CLKIN+.



### 3.3. Timing Characteristics

#### 3.3.1. Timing Conditions

Switching Characteristics

(recommended operating condition unless otherwise noted)

Item	Symiol	Values			Unit	Remark
		Min.	Typ.	Max.		
RxCLKIN Period	t <sub>RCP</sub>	11.76	T	50	ns	Note 1
RxCLKIN High Time	t <sub>RCH</sub>	-	T/2	-	ns	
RxCLKIN Low Time	t <sub>RCL</sub>	-	T/2	-	ns	
PAD0/1 to RxCLKIN Delay	t <sub>RCD</sub>	-	3T/7	-	ns	
Data Setup to RxCLKIN	t <sub>RS</sub>	1.9	-	-	ns	
Data Hold from RxCLKIN	t <sub>RH</sub>	3.0	-	-	ns	
Input Data Position 0(T=11.76ns)	T <sub>RIP1</sub>	-0.4	0	0.4	ns	Note 2
Input Data Position 1(T=11.76ns)	T <sub>RIP0</sub>	T/7-0.4	T/7	T/7+0.4	ns	Note 2
Input Data Position 2(T=11.76ns)	T <sub>RIP6</sub>	2T/7-0.4	2T/7	2T/7+0.4	ns	Note 2
Input Data Position 3(T=11.76ns)	T <sub>RIP5</sub>	3T/7-0.4	3T/7	3T/7+0.4	ns	Note 2
Input Data Position 4(T=11.76ns)	T <sub>RIP4</sub>	4T/7-0.4	4T/7	4T/7+0.4	ns	Note 2
Input Data Position 5(T=11.76ns)	T <sub>RIP3</sub>	5T/7-0.4	5T/7	5T/7+0.4	ns	Note 2
Input Data Position 6(T=11.76ns)	T <sub>RIP2</sub>	6T/7-0.4	6T/7	6T/7+0.4	ns	Note 2

Note 1: T= RxCLKIN Period

Note 2 : VDD=3.3V , Ta=25°C

**3.3.2. Timing Diagram**

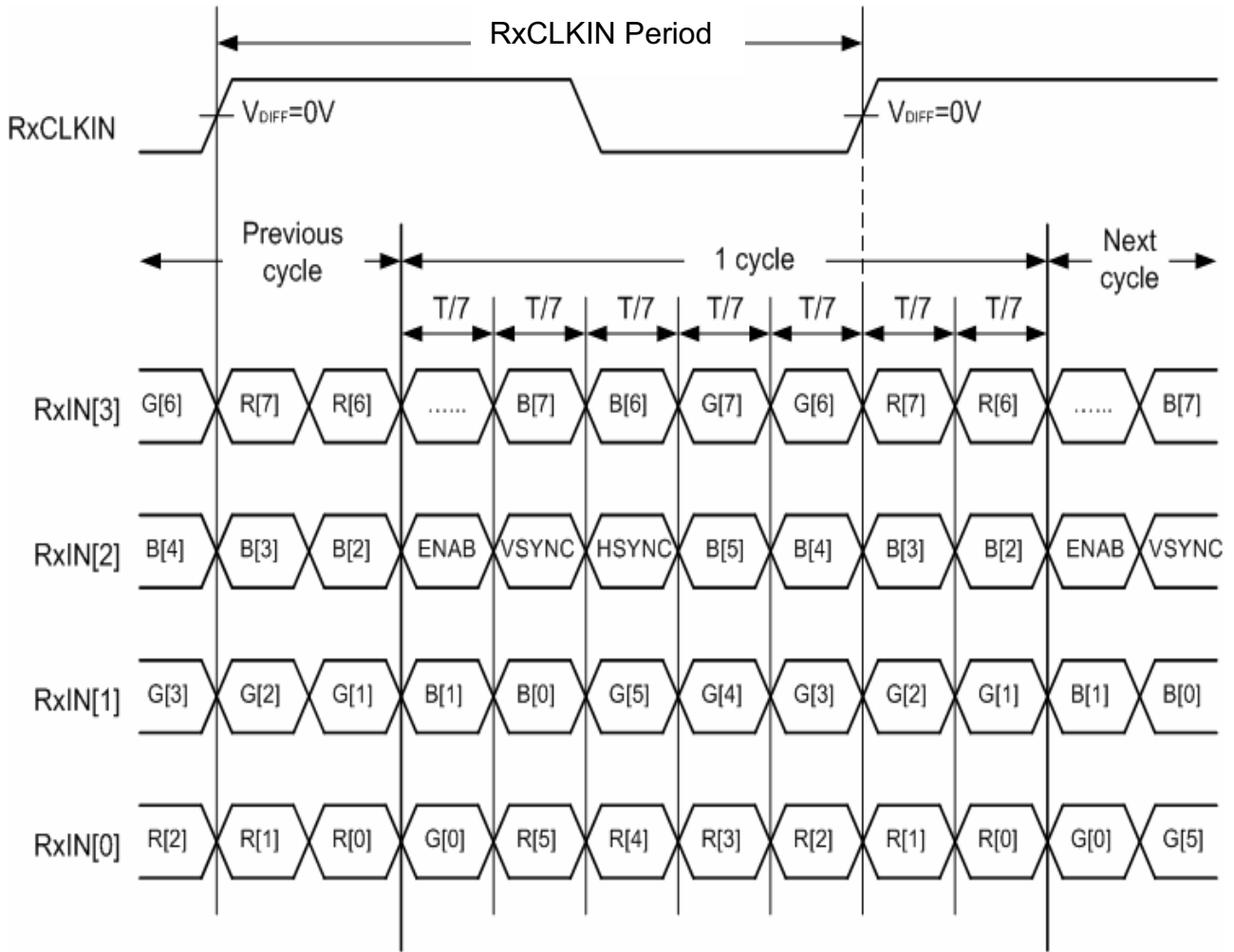

**Note : R/G/B[7]s are MSBs and R/G/B[0]s are LSBs**

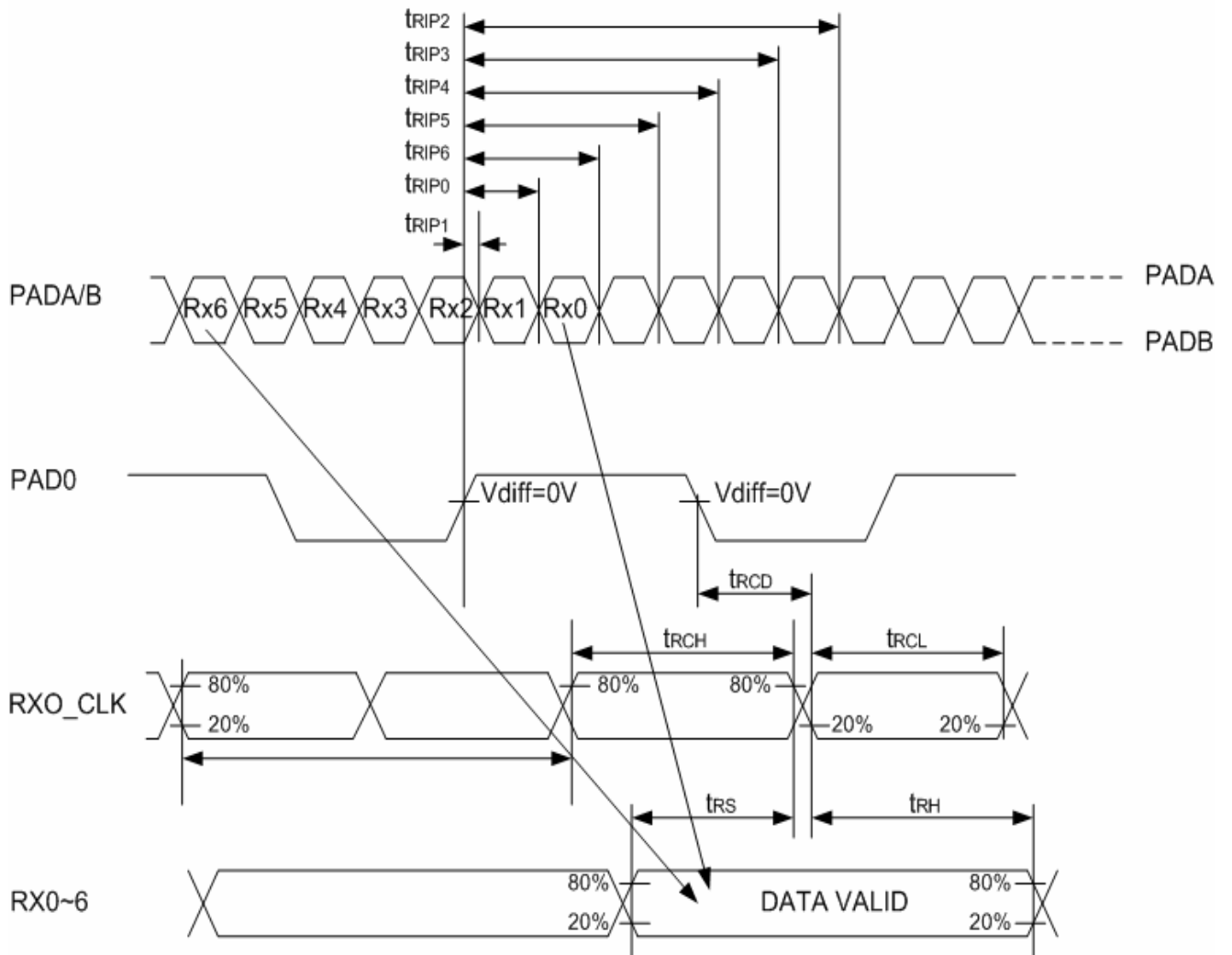

**LVDS AC Timing Diagrams**

## 4. Optical Specifications

Item	Symiol	Condition	Values			Unit	Remark
			Min.	Typ.	Max.		
Viewiny anyle (CR≥ 10)	$\theta_L$	$\Phi=180^\circ$ (9 o'clock)	70	80	-	deyree	Note 1
	$\theta_R$	$\Phi=0^\circ$ (3 o'clock)	70	80	-		
	$\theta_T$	$\Phi=90^\circ$ (12 o'clock)	60	70	-		
	$\theta_B$	$\Phi=270^\circ$ (6 o'clock)	70	80	-		
Response time	$T_{ON}$	Normal $\theta=\Phi=0^\circ$	-	10	20	msec	Note 3
	$T_{OFF}$		-	15	30	msec	Note 3
Contrast ratio	CR		400	500	-	-	Note 4
Color chromaticity	$W_X$		0.26	0.31	0.36	-	Note 2 Note 5 Note 6
	$W_Y$		0.28	0.33	0.38	-	
Luminance	L		250	300	-	-	Note 6
Luminance uniformity	$Y_U$		70	75	-	%	Note 7

**Test Conditions:**

1. Viewiny anyle is tested when  $V_{black}=4.9V$ ;  $V_{white}=0.6V$
2.  $V_{CC}=3.3V$ ,  $I_L=20mA$  (Backliht current), the ambient temperature is  $25^\circ C$ .
3. The test systems refer to Note 2.

Note 1: Definition of viewiny anyle raneye

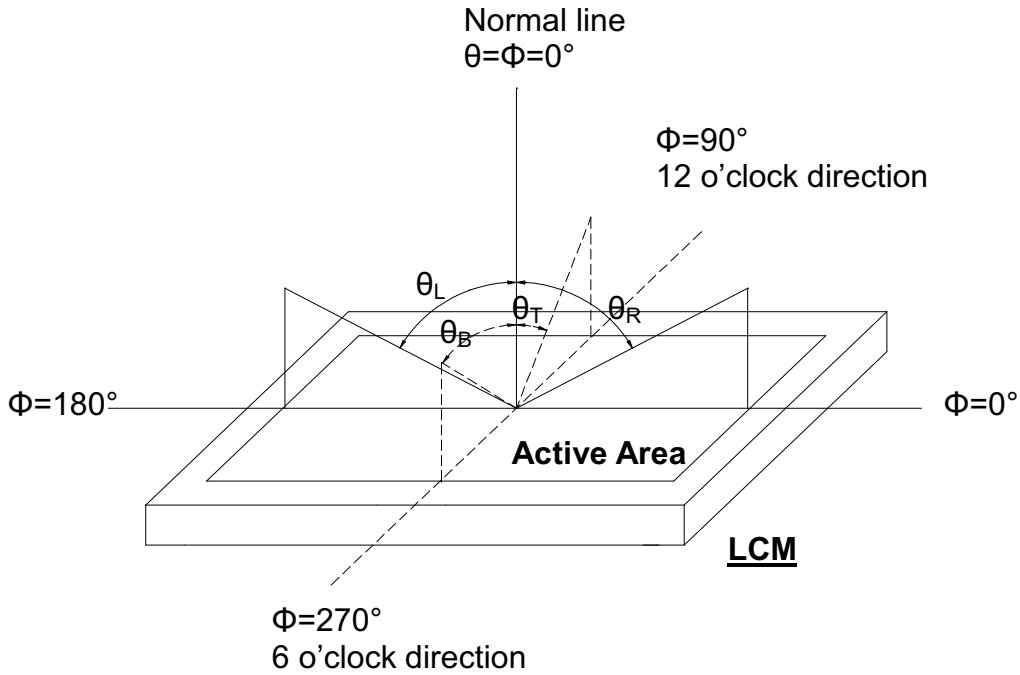

Fig. 4-1 Definition of viewiny anyle

Note 2: Definition of optical measurement system.

The optical characteristics should be measured in dark room. After 30 minutes operation, the optical properties are measured at the center point of the LCD screen. (Viewiny anyle is measured by ELDIM-EZ contrast/Heiyht :1.2mm ,Response time is measured by Photo detector TOPCON BM-7, other items are measured by BM-5A/ Field of view:  $1^\circ$  /Heiyht: 500mm.)

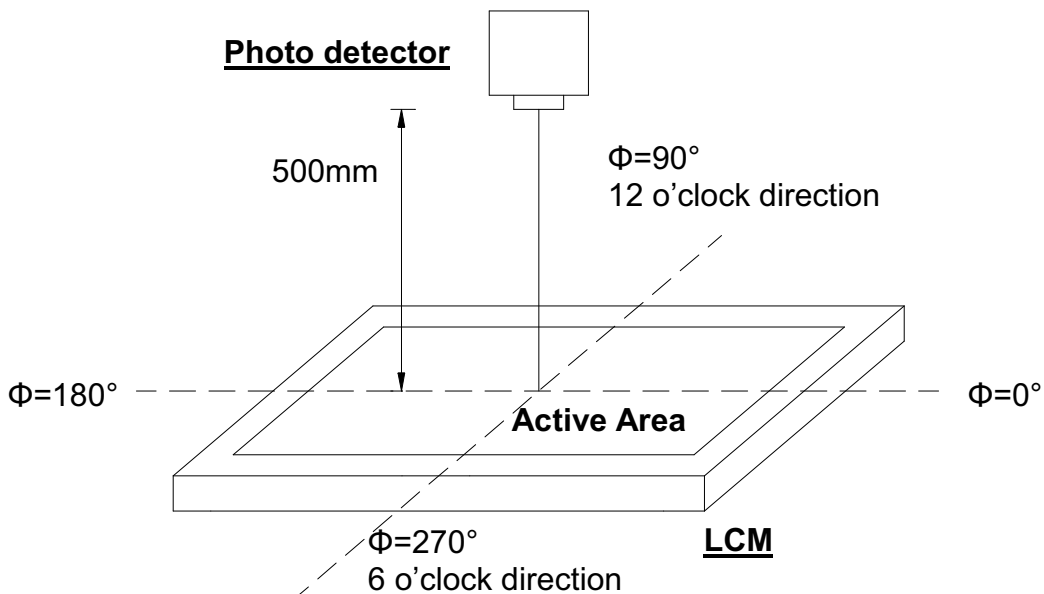

Fig. 4-2 Optical measurement system setup

**Note 3: Definition of Response time**

The response time is defined as the LCD optical switching time interval between "White" state and "Black" state. Rise time ( $T_{ON}$ ) is the time between photo detector output intensity changed from 90% to 10%. And fall time ( $T_{OFF}$ ) is the time between photo detector output intensity changed from 10% to 90%.

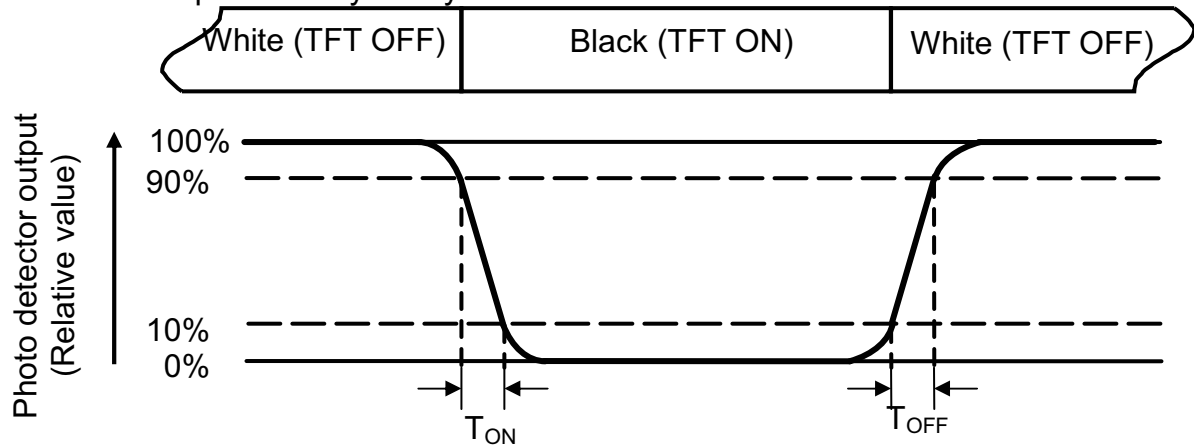

Fig. 4-3 Definition of response time

**Note 4: Definition of contrast ratio**

$$\text{Contrast ratio (CR)} = \frac{\text{Luminance measured when LCD on the "White" state}}{\text{Luminance measured when LCD on the "Black" state}}$$

**Note 5: Definition of color chromaticity (CIE1931)**

Color coordinates measured at center point of LCD.

Note 6: All input terminals LCD panel must be ground while measuring the center area of the panel. The LED driving condition is  $I_L=20\text{mA}$  of which each LED module is 3 LED serial.

## Note 7: Definition of Luminance Uniformity

Active area is divided into 9 measuriny areas (Refer to Fig. 4-4 ).Every measuriny point is placed at the center of each measuriny area.

$$\text{Luminance Unif)rmity (Yu)} = \frac{B_{min}}{B_{max}}$$

L-----Active area lenyth      W----- Active area width

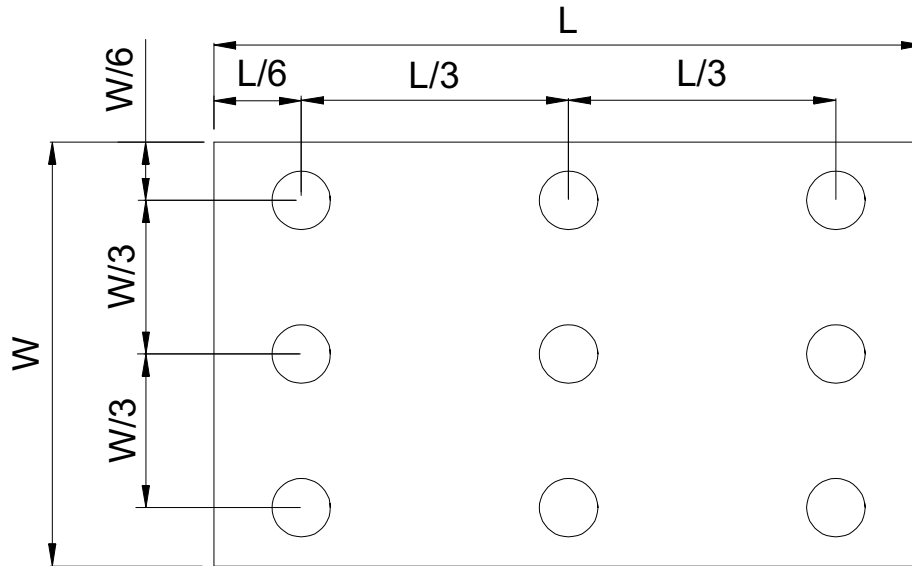

Fig. 4-4 Definition of measuriny points

**B<sub>max</sub>**: The measured maximum luminance of all measurement position.

**B<sub>min</sub>**: The measured minimum luminance of all measurement position.

## 5. Reliability Test Items

(Note3)

Item	Test Conditions	Remark
High Temperature Storagee	Ta = 80°C 240 hrs	Note 1,Note 4
Low Temperature Storagee	Ta =-30°C 240hrs	Note 1,Note 4
High Temperature Operation	Ts = 70°C 240hrs	Note 2,Note 4
Low Temperature Operation	Ta =-20°C 240hrs	Note 1,Note 4
Operate at High Temperature and Humidity	+40°C, 90%RH max.      240 hrs	Note 4
Thermal Shock	(-30)°C/30 min ~ (+80)°C/30 min for a total 100 cycles, Start with cold temperature and end with high temperature.	Note 4
Vibration Test	Frequency ranqe:10~55Hz Stroke:1.5mm Sweep:10Hz~55Hz~10Hz 2 hours for each direction of X. Y. Z. (6 hours for total)	
Mechanical Shock	100G 6ms,±X, ±Y, ±Z 3 times for each direction	
Packaye Vibration Test	Random Vibration : 0.015G*G/Hz from 5-200HZ, -6dB/Octave from 200-500HZ 2 hours for each direction of X. Y. Z. (6 hours for total)	
Packaye Drop Test	Heiyht:60 cm 1 corner, 3 edyes, 6 surfaces	
Electro Static Discharye	± 2KV, Human Body Mode, 100pF/1500Ω	

Note 1: Ta is the ambient temperature of samples.

Note 2: Ts is the temperature of panel's surface.

Note 3: In the standard condition, there shall be no practical problem that may affect the display function. After the reliability test, all the measurement shall be executed after the product is left alone for two hours; and the product only yuarantees operation, but dosen't yuarantee all the cosmetic specification.

Note 4: Before cosmetic and function tests , the product must have enough recovery time, at least 2 hours at room temperature.



## **6. General Precautions**

### **6.1. Safety**

Liquid crystal is poisonous. Do not put it in your mouth. If liquid crystal touches your skin or clothes, wash it off immediately by using soap and water.

### **6.2. Handling**

1. The LCD panel is plate glass. Do not subject the panel to mechanical shock or to excessive force on its surface.
2. The polarizer attached to the display is easily damaged. Please handle it carefully to avoid scratch or other damages.
3. To avoid contamination on the display surface, do not touch the module surface with bare hands.
4. Keep a space so that the LCD panels do not touch other components.
5. Put cover board such as acrylic board on the surface of LCD panel to protect panel from damages.
6. Transparent electrodes may be disconnected if you use the LCD panel under environmental conditions where the condensation of dew occurs.
7. Do not leave module in direct sunlight to avoid malfunction of the ICs.

### **6.3. Static Electricity**

1. Be sure to ground module before turning on power or operating module.
2. Do not apply voltage which exceeds the absolute maximum rating value.

### **6.4. Storage**

1. Store the module in a dark room where must keep at  $25\pm 10^{\circ}\text{C}$  and 65%RH or less.
2. Do not store the module in surroundings containing organic solvent or corrosive gas.
3. Store the module in an anti-electrostatic container or bag.

### **6.5. Cleaning**

1. Do not wipe the polarizer with dry cloth. It might cause scratch.
2. Only use a soft cloth with IPA to wipe the polarizer, other chemicals might permanent damage to the polarizer.

## 7. Mechanical Drawing

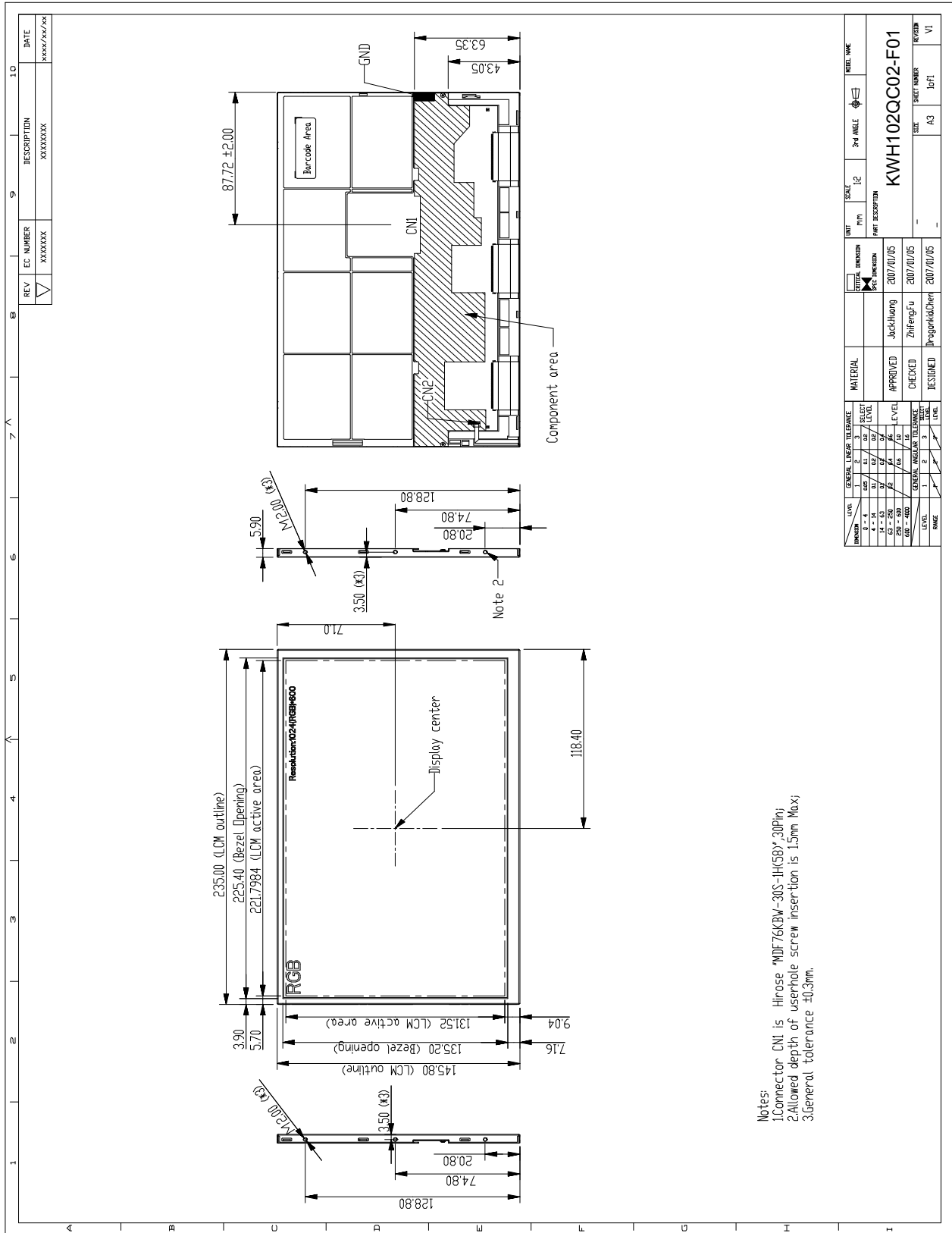

- Notes:
- 1.Connector CNI is Hirose \*MDF76KBV-30S-IH(58)\* 30Pin;
  - 2.Allowed depth of userhole screw insertion is 1.5mm Max;
  - 3.General tolerance ±0.3mm.

REVISION		DATE	
REV	EC NUMBER	DESCRIPTION	DATE
	XXXXXX	XXXXXXXX	XXXX/XX/XX

LEVEL	1	2	3	4	5	6	7	8	9	10
GENERAL	1	2	3	4	5	6	7	8	9	10
LINEAR	0.1	0.1	0.1	0.1	0.1	0.1	0.1	0.1	0.1	0.1
ANGULAR	0.5	0.5	0.5	0.5	0.5	0.5	0.5	0.5	0.5	0.5
POSITION	0.1	0.1	0.1	0.1	0.1	0.1	0.1	0.1	0.1	0.1
FORM	0.1	0.1	0.1	0.1	0.1	0.1	0.1	0.1	0.1	0.1
FINISH	0.1	0.1	0.1	0.1	0.1	0.1	0.1	0.1	0.1	0.1

UNIT	SCALE	3rd ANGLE	PROJ. SYM.
MM	1:2		

MATERIAL	APPROVED	CHECKED	DESIGNED
	Jack-Huang	Zhi-Feng-Fu	Prong-Hid-Chen

ITEM	DESCRIPTION	DATE	REVISION
1	KWH102QC02-F01	2007/11/05	V1

## 8. Package Drawing

### 8.1. Packaging Material Taile

No.	Item	Model (Material)	Dimensions(mm)	Unit Weight (kg)	Quantity	Remark
1	LCM Module	AT102TN43	235.0X145.8X5.9	0.258	25pcs	
2	Partition	BC Corruyated paper	512X349X226	1.350	1	
3	Partition Paper	B Corruyated paper	510X350X7	0.148	2	
4	Corruyated Bar	B Corruyated paper	512X370X7	0.110	2	
5	Dust-Proof Bay	PE	900X700X0.05	0.010	1	
6	A/S Bay	PE	280X200X0.05	0.001	25	$10^9 \sim 10^{11} \Omega/\text{sq}$
7	Carton	Corruyated paper	530X355X255	1.100	1	
8	Total weiyht	9.451ky $\pm$ 5%				

### 8.2. Packaging Quantity

Total LCM quantity in Carton: no. of Partition 1 Rows x quantity per Row 25 = 25
--

## **8.3. Packaging Drawing**

**TBD**