

CUSTOMER	CUSTOMER P/N	YC SP/N
2005		CS2005-0187

**RoHS Compliant**

REVISIONS					
REV	ECN NO.	DESCRIPTION	DATE	REVISER	APPD
1.0		Release to production	2011.08.05	Fred	

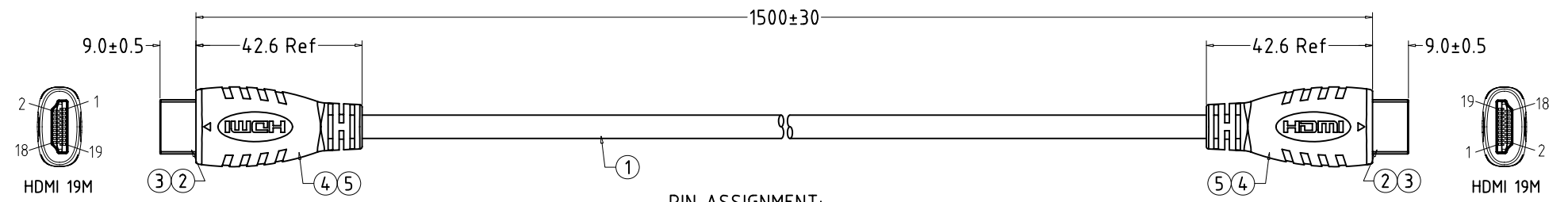

**PIN ASSIGNMENT:**

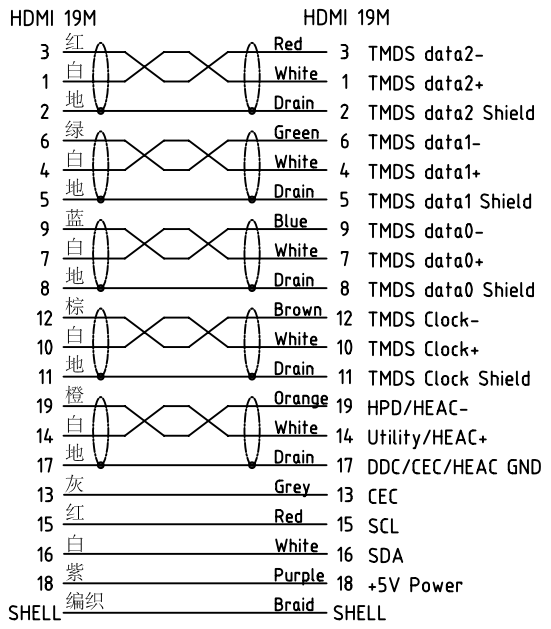

Electrical character:  
 1)100% Open&short testing  
 2)Withstanding voltage:DC 300V 0.01Sec  
 3)Insulation resistance:5M Ohm(min)  
 4)Residual operating current:  
     a.<1.M=0.5mA;   b.1.0~2.0M=1.0mA;  
     c.2.0~3.0M=2.0mA; d.3.0~5.0M=3.0mA  
 5)Conductive resistance:2 Ohm(max)

**APPROVED BY CUSTOMER:**

INNERMOLD NO. M1HDMIP1001	OVERMOLD NO. M2HDMIP1001
APPROVALS	
DRAWN	DATE
Fred	2011.08.05
CHECKED	
APPROVED	

**CZT YIHUA CABLEPLUS**  
 COMMUNICATION CABLES CO.,LTD

SCALE NONE	SHEET 1/1
UNIT mm	REV 1.0

NAME HIGH SPEED HDMI  
 CABLE WITH ETHERNET(30#)

DRAWING NO. CS2005-0187

NO.	PART NAME	SPEC DESCRIPTION	PART P/N	REMARK
5	Overmold	PVC 60Pa Black UL94V-0	PS02-601A01	
4	Innermold	PE Low density	PS00-00NN01	
3	Conn/Shell	HDMI A Male Shell: Steel Gold Plated	C010F-001	
2	Conn/Body	HDMI A Male Body: Pin G/F Black Lcp Insulation Solder/Solder added type	C010L-001	
1	Cable	UL20276(1P×28#TS+D+A+M)×5P+4C×28#TS+A+B(Al-Mg Alloy/65%) OD7.3±0.20mm PVC Jacket: Black Impedance:100+/-10 Ohm	-----	

# CONFIRMATION OF HDMI™ ATC TESTING

This Tested Product identified below has successfully completed testing at the HDMI Authorized Test Center with respect to the Test Specification listed below.

## PARTICIPANT

Contact: Sandy Zhao

Company: YiHua cableplus Communication Cables  
(DongGuan) Co.,Ltd.

Address: Hengzhong Road,Xin'an  
Community,Chang'An Town DongGuan  
City,GuangDong Province CHINA

Phone: 0086-769-85371358-8998

Email: cable@czt.com.cn

## TEST CONFIRMATION

Date of Issue: Mar 7, 2008

Test Center: Shenzhen

### Notes:

1. This confirmation is subject to the terms and conditions of the Authorized Test Center Agreement, and does not guarantee the quality or functionality of any product, compliance with any specification, or interoperability with other HDMI products. Participant is solely responsible for the quality, functionality, interoperability and specification conformance of Participant's products.
2. This confirmation is based upon the information Participant has supplied and Participant's representation that the products listed under "Derivative Model Names" have the same hardware and software as the Tested Product and would successfully pass all the HDMI ATC tests.

## TESTED PRODUCT

Category (i.e. Source, Sink, Repeater, Cable): Cable(cat 2)

Parent Model Name(s): cable assembly

Parent Model Number(s): HDMI CABLE 28AWG(3m)

Derivative Model Name(s) and Number(s) (supplied by Participant, not tested):

HDMI CABLE 28AWG(2.5m)  
HDMI CABLE 28AWG(2.0m)  
HDMI CABLE 28AWG(1.83m)  
HDMI CABLE 28AWG(1.5m)

Test Specification: 1.3b

Confirmed by: Dat Tran

**HDMI™**  
HIGH-DEFINITION MULTIMEDIA INTERFACE

**Certificate SZ#583**