

# ◆ SPECIFICATION

DESCRIPTION	UL2896 - 40N × 100mm * 0.5p * (4/4 , 8/8) * (0.05*0.32) * P7		
KRT PART NO.		DRAWING NO.	

## ▶ CABLE TYPE (PATTERN : 7 )

## ▶ CABLE DIMENSION [unit : mm]

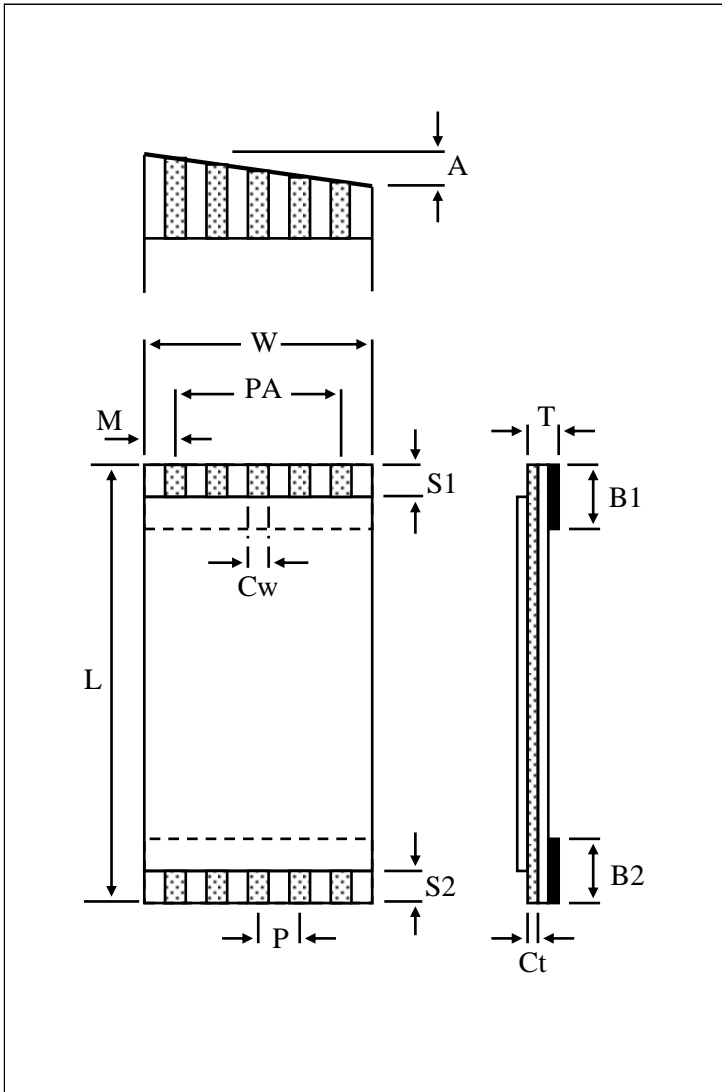

DESCRIPTION	Abbr	Dimension	Tolerance
PITCH	P	0.5	± 0.05
NO. OF CONDUCTOR	N	40	-
CABLE LENGTH	L	100	±3.00
STRIP LENGTH	S1	4	± 1.0
	S2	4	± 1.0
S/T LENGTH	B1	8	± 2.00
	B2	8	± 2.00
INSERT THICK	T	0.3	± 0.05
WIDTH	W	20.50	± 0.10
SPAN	PA	19.50	± 0.10
MARGIN	M	0.50	± 0.10
CONDUCTOR THICK	Ct	0.05	± 0.01
CONDUCTOR WIDTH	Cw	0.32	± 0.03
LESS THAN	A	0.5	-
PLATED	PL	1 $\mu$ m ↑	

## ⊙ REMARK

**KORA TECH CO., LTD.**

## Data input

STYLE	N	TL	P	S1	S2	B1	B2	Ct	Cw	pattern
UL2896	40	100	0.50	4	4	8	8	0.050	0.32	7

1. 위의 값들을 입력한다