

SPECIFICATION	CONNECTION	UNIPOLAR
AMPS/PHASE		0.50
RESISTANCE/PHASE(Ohms)@25°C		13.50±10%
INDUCTANCE/PHASE(mH)@1KHz		2.50±20%
HOLDING TORQUE w/o GEARBOX(Nm)[lb-in]		0.018[0.16]
GEAR RATIO		90,25
EFFICIENCY		73.00%
STEP ANGLE w/o GEARBOX(°)		1.80
BACKLASH@NO-LOAD		<=1°
MAX.PERMISSIBLE TORQUE(Nm)		0.90
MOMENT PERMISSIBLE TORQUE(Nm)		2.00
SHAFT MAXIMUM AXIAL LOAD(N)		5.00
SHAFT MAXIMUM RADIAL LOAD(N)		25.00
WEIGHT(Kg)[lb]		—
TEMPERATURE RISE:MAX,80°C (MOTOR STANDSTILL;FOR 2PHASE ENERGIZED)		
AMBIENT TEMPERATURE -10°C~50°C[14°F~122°F]		
INSULATION CLASS B 130°C[266°F]		

STEP	A	B	\bar{A}	\bar{B}	O(\bar{O})	CW
1	-	-			+	↓
2		-	-		+	
3			-	-	+	
4	-			-	+	
1	-	-			+	

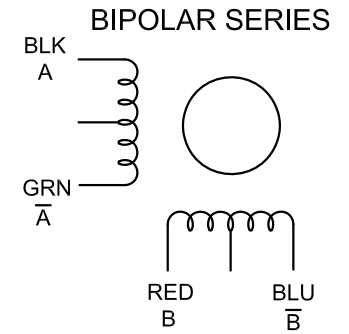
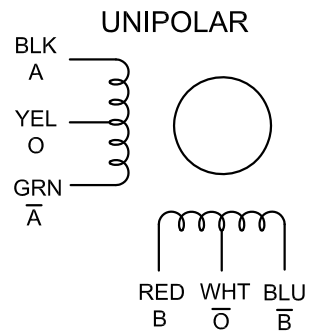

APVD		4.8.2021
CHKD		
1.5:1	DRN	
SCALE	SIGNATURE	DATE

STEPPER MOTOR
8HS12-0506S-PG90